

STATIC DIMENSIONS

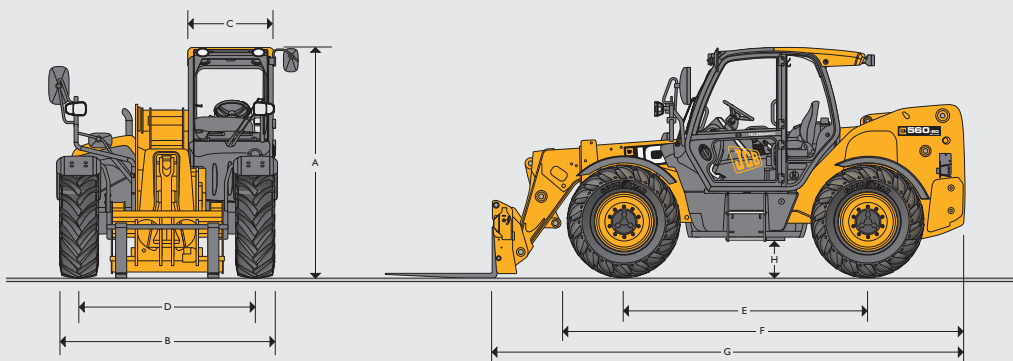

		550-80	560-80
A	Overall height	m	2.59
B	Overall width (over tyres)*	m	2.42
C	Inside width of cab	m	0.94
D	Front track	m	1.98
E	Wheelbase	m	2.75
F	Overall Length to front of tyres	m	4.42
G	Overall length to front of carriage	m	5.27
H	Ground clearance	m	0.4
	Outside turn radius (over tyres)	m	4.1
	Carriage rollback angle	degrees	47
	Carriage dump angle	degrees	33
	Weight	kg	10150
	Tyres		440/80 R24
			500/70 R24

* Dependant upon tyre specified

LIFT PERFORMANCE

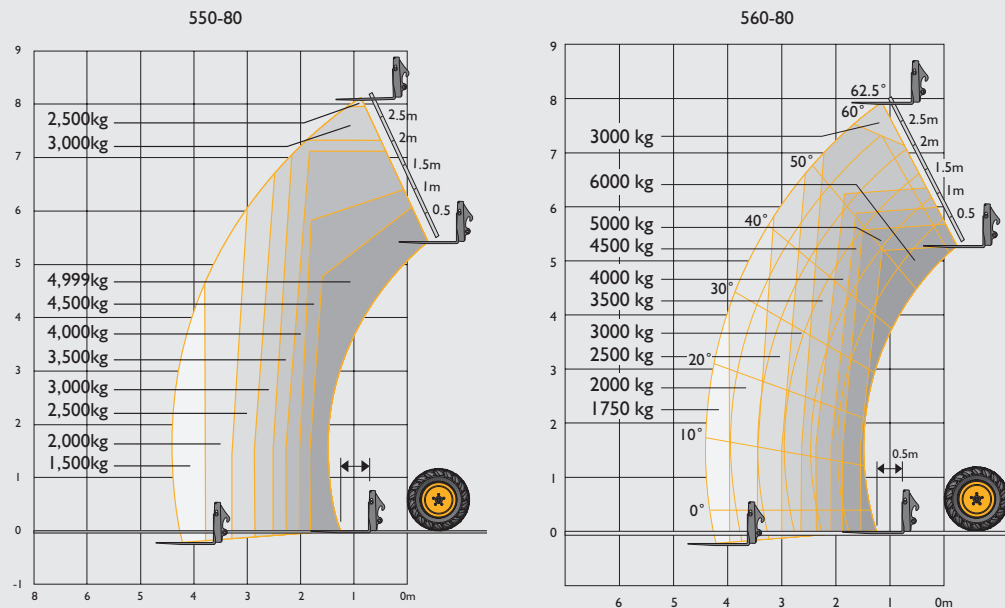

		550-80	560-80
	Maximum lift capacity	kg	4999
	Lift capacity to full height	kg	2500
	Lift capacity at full reach	kg	1500
	Lift height	m	8.1
	Reach at maximum lift height	m	0.97
	Maximum forward reach	m	4.47
	Reach with 1 tonne load	m	4.47
	Placing height	m	7.45
			6.64

Complies with stability test EN 1459 Annex B.

ENGINE		
Emissions level		Stage IIIb / Tier 4i
Manufacturer		JCB
Displacement	litres	4.4/4.8
No of Cylinders		4
Bore size	mm	103/106
Stroke	mm	132/135
Aspiration		TCA
Power rating		
Power @ 2200rpm	kW (hp)	93 (125)/108 (145)
Torque rating		
Torque @ 1500rpm	Nm (lb/ft)	550 (406)/560 (413)
Engine oil service intervals		500 hours

TRANSMISSION	
JCB powershift transmission incorporating torque converter, bevel box and a 4 speed powershift gearbox in one resiliently mounted unit. Manual gear shift incorporated onto the single lever joystick. Travel speed 38kph (dependant upon tyre selection). Permanent 4 wheel drive. Front and rear drive axles: Epicyclic hub reduction drive/steer axles with torque proportioning differentials.	

HYDRAULICS		
Operating system pressure	bar	260
Main hydraulics	l/min	14
Pump	l/min	Variable
Maximum auxiliary flow @ 230 bar	l/min	47.6
Loader controls	Cab mounted single lever joystick (Seat mounted optional) – Electric servo control of all lift end functions.	
Hydraulic cycle times	seconds	
	550-80	560-80
Boom raise	7.4	
Boom lower	5.9	8.3
Extend	8.3	
Retract	5.9	
Bucket dump	2.8	
Bucket crowd	3	

ELECTRICAL SYSTEM		
System voltage	Volt	12
Alternator output	Amp hour	95
Battery capacity	Amp hour	110

SERVICE CAPACITIES		
Fuel tank	litres	146
Hydraulic tank	litres	112
Engine oil sump	litres	14
Engine coolant system	litres	23

BRAKES
Service brakes: Hydraulically activated power brakes, self-adjusting, oil-immersed in-board multi-disc type on front and rear axles.
Parking brake: Hand operated oil immersed disc type.

BOOM AND CARRIAGE
Boom is manufactured from high tensile steel. Low maintenance, hard wearing pads. JCB Q-fit self-levelling carriage with lever operated pin locking accepts pallet forks and a wide range of attachments. One boom end auxiliary hydraulic service fitted as standard.

SAFETY CHECK VALVES
Fitted to carriage tilt, telescopic and boom lift rams.

ELECTRICS
12V negative earth. 110 AH battery. 95 amp alternator. Full road lighting. Reversing light. Directional indicators. Hazard warning. Reverse alarm.

NOISE AND VIBRATION		
		Measurement conditions
Noise at the operator station (LpA)	78dB	In accordance with ISO6369 in a test defined in 2000/14/EC
Noise emission from the machine (LWA)	107dB	External noise determined in accordance with test defined in 2000/14/EC
Whole body vibrate emission	0.42m ²	In accordance with ISO 2631-1:1997

STEERING

Hydrostatic power steering with power track rods on both axles. Three steer mode options: front wheel steer; all wheel steer; crab steer: operated from in the cab by a selection switch, with automatic alignment.

CAB

Quiet, safe and comfortable cab conforms to ROPS ISO 3471 and FOPS ISO 3449. Tinted glass all round with laminated front and roof screen. Roof bars, front, rear and roof screen wash/wipe and heater/screen demister. Opening rear window. Audio-visual warning system for coolant temperature, water in fuel, engine oil pressure, air cleaner, battery charge, transmission oil temperature and pressure. Brake charge, hourmeter and road speed indicator. Engine temperature, fuel gauge and clock. Adjustable steer column with stalk bar powershift change and forward reverse shuttle. Floor mounted throttle pedal. Adjustable deluxe suspension seat with adjacent park brake. Automatic eye level audio-visual load moment indicator warning system receiving a signal from a load sensor on the rear axle. This system continuously monitors the machine's forward stability and leaves the operator in control at all times.

Hydraulic controls: Cab mounted single lever servo joystick, incorporating forward/neutral/reverse, transmission disconnect, with progressive extend/retract and auxiliary incorporating constant flow facility. Seat mounted single lever servo joystick incorporating forward/neutral/reverse, transmission disconnect, with progressive extend/retract and auxiliary incorporating constant flow facility (optional).

OPTIONS AND ACCESSORIES

Options: Front, rear and boom working lights, rotating flashing beacon, fire extinguisher, 26" agricultural and industrial tread pattern tyre option, 120 AH battery, radial industrial tyres, electrical 2/4WD select, limited slip differential in front axle, windscreen and roof guard, air suspension seat, roof and front screen blind, radio kit, air conditioning, 2 speed and intermittent front wash/wipe, high flow auxiliary, Smoothride system, towing facility with trailer lighting package, direct mount bucket, variable speed fan and reversing fan as standard, optional auto reverse fan, 2nd boom auxiliary, carriage options available – contact your local dealer.

Attachments: Contact your local dealer for details of the comprehensive range. Adaptive load control for EU territories conforms to EN15000.

OPTIONS CHART

Machine model		550-80	550-80 BIOMASTER	560-80	560-80 BIOMASTER
Standard features	Regenerative hydraulics (lower & retract)	●	●	●	●
	End damping (lift, lower, extend & retract)	●	●	●	●
	Quick aux venting	●	●	●	●
	Increased diameter pipework all boom functions - 1/2" to 5/8"	●	●	●	●
	Bucket control system	●	●	●	●
Options	Auto SRS	○	○	○	○
	Rockinger hitch range (6 types)	○	○	○	○
	LED work lights (front & rear)	○	●	○	●
	LED boom works lights (boom)	○	●	○	●
	Rear hitch light	Standard: If hitch selected	Standard: If hitch selected	Standard: If hitch selected	Standard: If hitch selected
	LED rear hitch light	Option: If hitch selected	Option: If hitch selected	Option: If hitch selected	Option: If hitch selected
	5.0 cum bucket	–	–	○	○
	Biomaster	Auto reversing fan	○	●	○
Boom nose cover		○	●	○	●
Air conditioning		○	●	○	●
Clean air kit		○	●	○	●
Remote greasing		○	●	○	●

Standard ● Option ○